

Gefen

®

HDMI™ CAT-5 MS Extreme Extender

EXT-HDMI-CAT5-MS

User Manual



www.gefen.com

ASKING FOR ASSISTANCE

Technical Support:

Telephone (818) 772-9100
(800) 545-6900

Fax (818) 772-9120

Technical Support Hours:

8:00 AM to 5:00 PM Monday thru Friday PST

Write To:

Gefen Inc.
c/o Customer Service
20600 Nordhoff St
Chatsworth, CA 91311

www.gefen.com
support@gefen.com

Notice

Gefen Inc. reserves the right to make changes in the hardware, packaging and any accompanying documentation without prior written notice.

HDMI CAT-5 MS Extreme is a trademark of Gefen Inc.

© 2010 Gefen Inc., All Rights Reserved.
All trademarks are the property of their respective companies.

Rev B1

CONTENTS

- 1 Introduction**
- 2 Operation Notes**
- 3 Features**
- 4 Sender Panel Descriptions**
- 5 Receiver Panel Descriptions**
- 6 Connecting and Operating the HDMI CAT-5 MS Extreme**
- 7 Service Switch Usage Guide**
- 8 Additional DIP Switch Functions**
- 9 Network Cable Wiring Diagram**
- 10 Mounting Plate Installation**
- 11 Terminology**
- 12 Specifications**
- 13 Warranty**

INTRODUCTION

Congratulations on your purchase of the HDMI CAT-5 MS Extreme. Your complete satisfaction is very important to us.

Gefen

Gefen delivers innovative, progressive computer and electronics add-on solutions that harness integration, extension, distribution and conversion technologies. Gefen's reliable, plug-and-play products supplement cross-platform computer systems, professional audio/video environments and HDTV systems of all sizes with hard-working solutions that are easy to implement and simple to operate.

The Gefen HDMI CAT-5 MS Extreme

The HDMI CAT-5 MS Extreme Extender extends your HDTV display up to 300 feet away from your HDTV source using two CAT-5 cables. It is equipped with HDMI (high definition multimedia interface) connectors and is capable of supporting DVI (digital visual interface) equipment when used with a HDMI to DVI Adapter, providing greater flexibility and options when integrating several home theater components.

How It Works

The HDMI CAT-5 Extreme-S sender unit sits next to your computer, set-top box or DVD player source. Cables supplied with the HDMI CAT-5 MS Extreme connect your DVI or HDMI source to the send unit. The HDMI CAT-5 Extreme-R receive unit sits next to your HDTV display - up to 300 feet away. The display plugs into the back of the HDMI CAT-5 MS Extreme-R receiver unit. Two CAT-5 cables connect the sender and the receiver units to each other.

OPERATION NOTES

READ THESE NOTES BEFORE INSTALLING OR OPERATING THE HDMI CAT-5 MS EXTREME

- The HDMI CAT-5 MS Extreme units are housed in a metal box for better RF shielding.
- Your CAT-5 cable should not exceed 300 feet.
- If you do not need DDC or HDCP data you can use a single CAT-5 cable for the video only. The DDC will not be connected. (For further information, see our Terminology section on page 11.) If HDCP is required, both CAT-5 cables must be used between the sender and receiver units.
- If the source requires EDID present, you can use the Gefen HDMI Detective to provide EDID information to your source but will not transmit HDCP.
- Shielded CAT-6 with metal RJ-45 connectors is recommended to protect from random flashes caused by EMI.
- Power supply for the receiver should not be connected unless you are using one CAT-5 or going over a distance of 200ft.
- Extensions over 130ft. require you to manually EQ your signal (see page 7).
- Extensions under 130ft. use Auto EQ (which is on by default) (see page 7).
- The extender is factory set to Auto EQ which will work for distances under 130 ft.
- This product features the option to force the output colorspace to RGB and/or use a pre-programmed EDID. These features can be used to resolve specific user issues or for troubleshooting purposes. Please see page 8 for more information.

FEATURES

Features

- Extends high definition displays up to 150 feet from the source at 1080p
- Extends high definition displays up to 300 feet from the source at 1080i
- Improved compensation for cable skew
- Eliminates equipment noise in the viewing environment
- Supports resolutions up to 1080p, 2K, and 1920 x 1200
- Audio and video are transmitted digitally over the CAT-5e cable for zero signal loss
- HDMI compliant
- HDCP compliant

Package Includes

- (1) HDMI CAT-5 MS Extreme Sender Unit
- (1) HDMI CAT-5 MS Extreme Receiver Unit
- (1) 6 foot HDMI cable (M-M)
- (2) 5V DC Power Supply
- (1) User Manual

SENDER PANEL DESCRIPTIONS

Front Panel

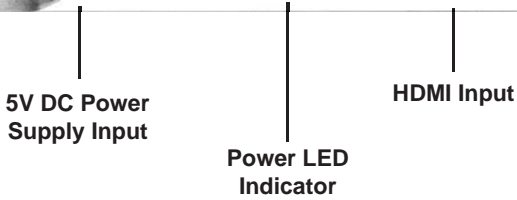

Back Panel

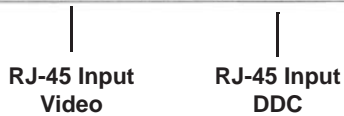

RECEIVER PANEL DESCRIPTIONS

Front Panel

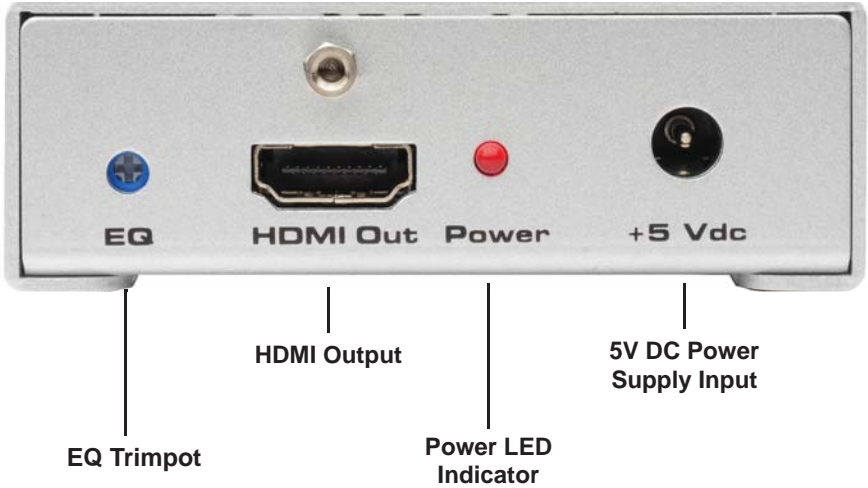

Back Panel

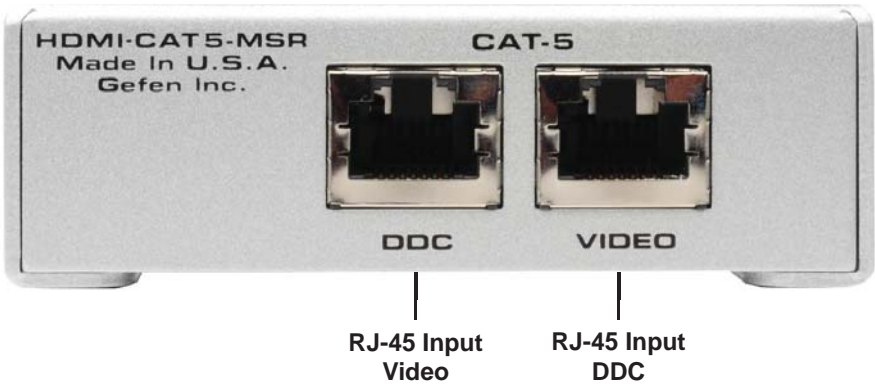

CONNECTING AND OPERATING THE HDMI CAT-5 MS EXTREME

1. Connect the HDMI source to the HDMI CAT-5 MS Extreme sending unit's HDMI input port using the supplied HDMI cable.
2. Connect the HDMI CAT-5 MS Extreme sending and receiving units together using two user supplied CAT-5, CAT-5e or CAT-6 cables.

NOTE: If field terminating network cable, please adhere to the TIA/EIA568B specification. Please see page 9 for more information.

3. Connect the display to the HDMI output port of the HDMI CAT-5 MS Extreme receiving unit using a user supplied HDMI cable.
4. Plug the 5V DC power supply into the HDMI CAT-5 MS Extreme sending unit.

NOTE: In most scenarios, the 5V DC external power supply for the receiving unit will not be required. Operational power is supplied by the sending unit via the connected CAT-5, CAT-5e or CAT-6 cable. If the power LED indicator on the receiving unit is not on, please check to make sure that the RJ-45 cables are not crossed (DDC to video and video to DDC).

5. Power on the display.
6. Power on the source.

AUTO EQUALIZATION

The HDMI CAT-5 MS Extreme has built-in auto equalization that will automatically tune out any unwanted video noise. This feature is reliable with premium cable runs up to a maximum of 130 feet. It may be necessary to disable this feature if there is either no video being displayed on initial start-up, there is video noise in the image, or the cable run exceeds 130 feet. First, verify that all the proper connections have been made and that all devices are powered on before attempting to disable auto equalization.

SERVICE SWITCH USAGE GUIDE

The sender and receiver units both have sets of DIP switches located on the underside of their casings. There is a piece of silver metallic tape that must be removed to expose these DIP switches. Each unit carries a bank of 4 DIP switches. Dip switches 1 and 2 on the sending unit and DIP switch 1 on the receiving unit are used in this procedure. By default, all DIP switches on the receiving units should be in the OFF position (Auto EQ On). DIP switch 2 on the sending unit should be in the ON position (No Boost). To turn off auto equalization, turn DIP switch 1 on the receiving unit to the ON position (Auto EQ off). With this setting please follow the steps below to equalize the picture.

1. Insert a small flat head tool into the trimpot on the receiver unit.
2. Turn the trimpot in a clockwise fashion until it comes to a stop. Do not force the trim pot beyond this point. Doing so may break the trim pot.
3. Slowly turn the trimpot counter-clockwise in millimeter increments until the image stabilizes and all video noise disappears.
4. Carefully remove the adjustment tool.

NOTE: If your cable run is beyond 130 feet, or the following steps do not produce any video, it may be necessary to increase the boost from the sending unit. Use the chart below to increase the boost by changing the sender DIP switches. Once a new boost setting is set, repeat steps 1 through 4 from above.

Sender DIP Switch Settings		
Setting	Switch 1	Switch 2
No Boost (Default)	OFF	ON
Medium Boost	OFF	OFF
High Boost	ON	OFF
Not Used	ON	ON

Receiver DIP Switch Settings		
Setting	Switch 1	Switch 2
Manual EQ	ON	OFF
Auto EQ (Default)	OFF	OFF

Adjustment Guidelines:

1. Strong boost should not be used on stranded cables. Strong boosting will cause pixels or no picture on these cables.
2. Using the wrong settings will not damage the units; it will either produce no image or a noisy image.
3. To eliminate the possibility of cross talk and interference, cables must be terminated with 568B scheduling. (See page 9 for details)
4. No Boost should be set when using Auto EQ.

ADDITIONAL DIP SWITCH FUNCTIONS

FORCE RGB AND PRE-PROGRAMMED EDID FEATURES

DIP switch 1 on the 4-bank DIP switch located on the underside of receiver unit enables and disables the automatic equalization function. Additional features can be enabled by using the other DIP switches on this bank.

Enabling DIP switch 3 will force the use of a pre-programmed EDID

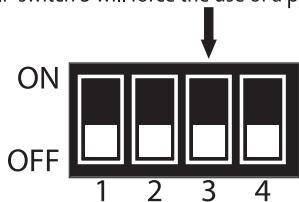

Enabling DIP switch 2 will force RGB on the output

FORCING THE RGB COLORSPACE

In some cases, the output video may have a pink or green tint. This usually is attributed to the output device (i.e. display) not supporting the colorspace being used by the source device. All digital displays will handle the standard RGB colorspace. DIP switch 2 can be enabled to force the output colorspace to RGB. If the input colorspace is YCbCr, the colorspace will be converted to RGB prior to output on the receiver unit.

USING THE PRE-PROGRAMMED EDID

In some cases it may be necessary to force an HDMI 1.2 EDID for troubleshooting purposes. Enabling DIP switch 3 will force the use of a pre-programmed EDID to be sent to the source instead of the connected output device (i.e. display). The EDID specifics are listed below.

Resolution	Timing
640x480	60Hz
720x480i/p	59.94/60Hz
720x576i/p	50Hz
1280x720p	50Hz
1280x720p	59.94/60Hz
1920x1080i/p	50Hz
1920x1080i/p	59.94/60Hz

Audio Format	Channels	Frequency
LPCM	2	32/44.1/48 kHz

NETWORK CABLE WIRING DIAGRAM

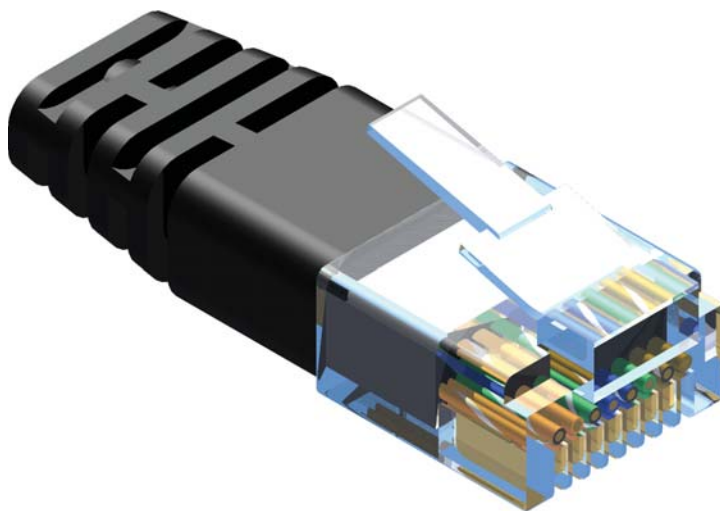

Gefen has specifically engineered their products to work with the TIA/EIA-568-B specification. Please adhere to the table below when field terminating cable for use with Gefen products. Failure to do so may produce unexpected results and reduced performance.

Pin	Color
1	Orange / White
2	Orange
3	Green / White
4	Blue
5	Blue / White
6	Green
7	Brown / White
8	Brown

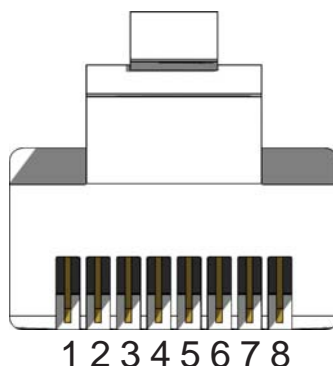

CAT-5, CAT-5e, and CAT-6 cabling comes in stranded and solid core types. Gefen recommends using solid core cabling. CAT-6 cable is also recommended for best results.

Each cable run must be one continuous run from one end to the other. No splices or use of punch down blocks.

Mounting Plate Installation

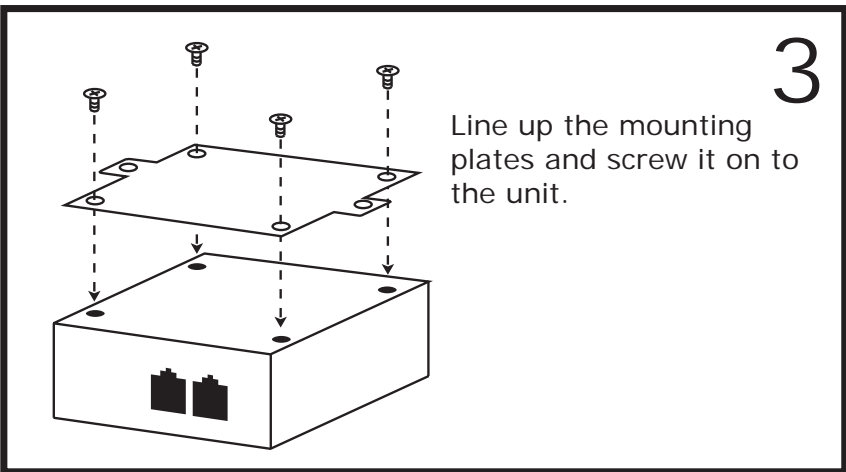
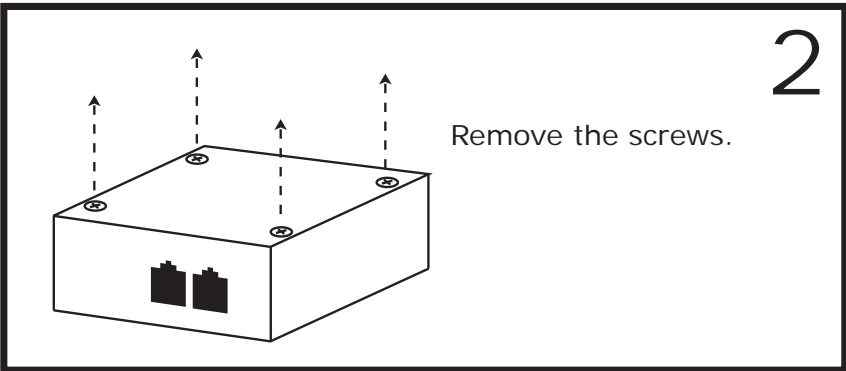
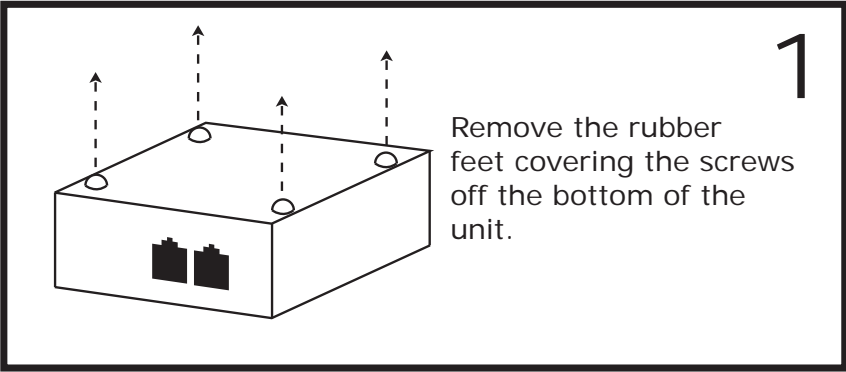

TERMINOLOGY

CAT-5

Category 5 cable, commonly known as Cat 5, is an unshielded twisted pair type cable designed for high signal integrity. The actual standard defines specific electrical properties of the wire, but it is most commonly known as being rated for its Ethernet capability of 100 Mbit/s. Its specific standard designation is EIA/TIA-568. Cat 5 cable typically has three twists per inch of each twisted pair of 24 gauge copper wires within the cable.

CAT-5e

Similar to Cat 5 cable, but is enhanced to support speeds of up to 1000 Megabits per second.

DDC

Short form for Display Data Channel. It is a VESA standard for communication between a monitor and a video adapter. Using DDC, a monitor can inform the video card about its properties, such as maximum resolution and color depth. The video card can then use this information to ensure that the user is presented with valid options for configuring the display.

DDWG

Digital Display Working Group DDWG are the creators of the DVI specification.

DVI

Digital Visual Interface. A digital video standard established by DDWG, which was designed to carry uncompressed digital video signals to a display.

HDMI

The High-Definition Multi-media Interface (HDMI) is an industry-supported, uncompressed, all-digital audio/video interface. HDMI provides an interface between any compatible digital audio/video source, such as a set-top box, DVD player, and A/V receiver and a compatible digital audio and/or video monitor, such as a digital television (DTV).

HDCP

High-Bandwidth Digital Content Protection. Created by Intel, HDCP is used with HDTV signals over HDMI and HDMI connections and on D-Theater D-VHS recordings to prevent unauthorized duplication of copy written material.

HDTV

High-Definition Television. The high-resolution subset of our DTV system. The ATSC defines HDTV as a 16:9 image with twice the horizontal and vertical resolution of our existing system, accompanied by 5.1 channels of Dolby Digital audio. The CEA defines HDTV as an image with 720 progressive or 1080 interlaced active (top to bottom) scan lines. 1280:720p and 1920:1080i are typically accepted as high-definition scan rates.

VESA

Video Electronic Standards Association, a consortium of manufacturers formed to establish and maintain industry wide standards for video cards and monitors. VESA was instrumental in the introduction of the Super VGA and Extended VGA video graphics standards with a refresh rate of 70 Hz, minimizing flicker and helping to reduce user eyestrain and fatigue.

SPECIFICATIONS

Video Amplifier Bandwidth	165 MHz
Input Video Signal	1.2 Volts p-p
Input DDC Signal	5 Volts p-p (TTL)
Single Link Range	1080p / 1920 x 1200
HDMI Connector Type	Type A 19 Pin Female
Link Connector	RJ-45
Power Consumption	10 Watts (max) per unit
Power Supply	5V DC
Dimensions	3.25" D x 3.25" W x 1.1" H
Shipping Weight	3 lbs.

WARRANTY

Gefen warrants the equipment it manufactures to be free from defects in material and workmanship.

If equipment fails because of such defects and Gefen is notified within two (2) years from the date of shipment, Gefen will, at its option, repair or replace the equipment, provided that the equipment has not been subjected to mechanical, electrical, or other abuse or modifications. Equipment that fails under conditions other than those covered will be repaired at the current price of parts and labor in effect at the time of repair. Such repairs are warranted for ninety (90) days from the day of reshipment to the Buyer.

This warranty is in lieu of all other warranties expressed or implied, including without limitation, any implied warranty or merchantability or fitness for any particular purpose, all of which are expressly disclaimed.

1. Proof of sale may be required in order to claim warranty.
2. Customers outside the US are responsible for shipping charges to and from Gefen.
3. Copper cables are limited to a 30 day warranty and cables must be in their original condition.

The information in this manual has been carefully checked and is believed to be accurate. However, Gefen assumes no responsibility for any inaccuracies that may be contained in this manual. In no event will Gefen be liable for direct, indirect, special, incidental, or consequential damages resulting from any defect or omission in this manual, even if advised of the possibility of such damages. The technical information contained herein regarding the features and specifications is subject to change without notice.

For the latest warranty coverage information, please visit Gefen's Warranty web page at <http://www.gefen.com/kvm/aboutus/warranty.jsp>

PRODUCT REGISTRATION

Please register your product online by visiting Gefen's web site at <http://www.gefen.com/kvm/Registry/Registration.jsp>

* ma - HDMI - CAT5 - MS*

Rev B1

20600 Nordhoff St., Chatsworth CA 91311

1-800-545-6900 818-772-9100 fax: 818-772-9120

www.gefen.com support@gefen.com

