



**4x4 HDMI  
Matrix  
USER MANUAL**

**[www.gefen.com](http://www.gefen.com)**

## ASKING FOR ASSISTANCE

---

### Technical Support:

Telephone (818) 884-6294  
(800) 545-6900

Fax (818) 884-3108

### Technical Support Hours:

9:00 AM to 5:00 PM Monday through Friday.

### Write To:

Gefen Inc.  
C/O Customer Service  
6265 Variel Ave.  
Woodland Hills, CA 91367-9897

### Notice

Gefen Inc. reserves the right to make changes in the hardware, packaging and any accompanying documentation without prior written notice.

**The 4x4 HDMI Matrix** is a trademark of Gefen Inc.

# TABLE OF CONTENTS

---

- 1** Introduction / Operation Notes
- 2** Features
- 3** Panel Layout
- 4** Using the 4x4 HDMI Matrix
- 5** RMT16-IR Installation
- 6** Dip Switch Guidelines
- 7** IR Codes
- 8** RS-232 Interface
- 9** 4x4 HDMI Matrix Rack Mount Diagram
- 10** Specifications
- 11** Terminology
- 12** Warranty

## INTRODUCTION

---

Thank you for purchasing the 4x4 HDMI Matrix.

The 4x4 HDMI Matrix switches four HDTV sources to any four HDMI displays.

The 4x4 HDMI Matrix switcher has four HDMI inputs and four HDMI outputs. Matrix input #1 and the HDMI port of HDTV source #1 connects using a male to male HDMI cable. The HDMI port of HDTV source #2 connects to HDMI input #2. The HDMI port of HDTV source #3 connects to HDMI input #3. The HDMI port of HDTV source #4 connects to HDMI input #4. There are four (4) HDMI outputs connecting to four (4) different displays.

Note: The switching is done by using either the the RMT-16-IR remote control or through the RS232 port. The 4x4 HDMI Matrix is rack mountable. Any HDTV with DVI inputs can be connected to the HDMI outputs of the matrix by using a DVI to HDMI adapter if the cable used is DVI.

## OPERATION NOTES

---

### READ THESE NOTES BEFORE INSTALLING OR OPERATING THE 4X4 HDMI MATRIX

- You should connect all the cables and power supply prior to connecting power to the HDTV sources and 4x4 HDMI Matrix.
- When powering the sources, the display needs to point to the source input.
- The 4x4 HDMI Matrix is housed in a metal box for better RF shielding.
- The 4x4 HDMI Matrix works with all DVI and HDMI displays.
- The 4x4 HDMI Matrix supports both AUDIO and VIDEO signals.
- The 4x4 HDMI Matrix is fully HDCP compliant.

# FEATURES

---

## Features

- Allows any HDMI display to view any source at any time
- Allows any source to be displayed on multiple displays at the same time
- Maintains resolutions up to 1080p, 2K, and 1920x1200
- Maintains highest HDMI single link video resolution
- Maintains highest HDMI digital audio signal
- Supports HDCP compliant devices
- HDMI or DVI to HDMI cables are used to connect the inputs and the matrix output
- Each display's inputs can be switched with the IR remote control or through RS232

## Includes:

- (1) 4x4 HDMI Matrix
- (4) HDMI 6ft Male to Male Cables
- (1) 24VDC Power Supply
- (1) User Manual
- (1) RMT-16IR Remote Control
- (1) Rack Ears



*Front Panel*



- Output-1 Display 1 LED Indicator
- Output-2 Display 2 LED Indicator
- Output-3 Display 3 LED Indicator
- Output-4 Display 4 LED Indicator
- IR Sensor
- IR Extender Eye Port
- Power Indicator

*Back Panel*

RS232 Controller Port

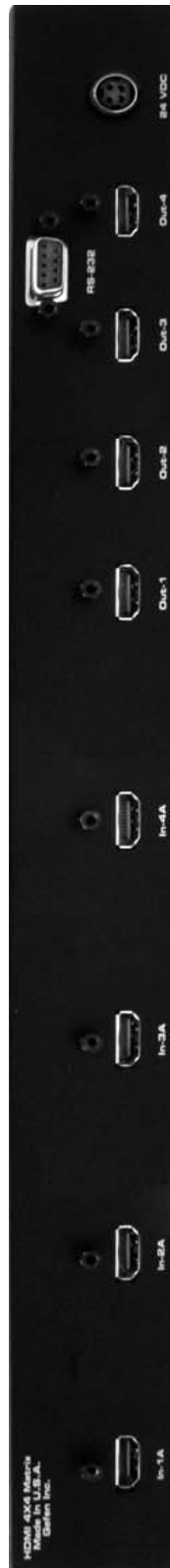

- In-1A
- In-2A
- In-3A
- In-4A
- Out-1
- Out-2
- Out-3
- Out-4
- RS-232
- 84-VDC
- HDMI Inputs
- HDMI Outputs
- Connects to 24VDC Power Supply

## USING THE 4X4 HDMI MATRIX

---

- 1 Connect all the sources to the HDMI inputs on the 4x4 HDMI Matrix, using the supplied cables.
- 2 Connect the HDMI/DVI displays to the outputs on the 4x4 HDMI Matrix.
- 3 Connect the 24VDC powersupply to the 4x4 HDMI Matrix
- 4 Controlling the 4x4 HDMI Matrix using the RMT16-IR:

Pressing Buttons...	Switches...
1-4	Display 1 to view Source 1, 2, 3, or 4
5-8	Display 2 to view Source 1, 2, 3, or 4
9-12	Display 3 to view Source 1, 2, 3, or 4
13-16	Display 4 to view Source 1, 2, 3, or 4

**\*Note for computers connected to the HDMI Matrix** - When your computer boots up, it looks for an EDID (extended display identification data) from the display to tell it what monitor is connected and what resolution to output. During boot up of the computer you should have ONLY one output selected to one input at a time so that the computer gets the EDID of the display that is selected. If you have multiple outputs selected to one computer, the computer will read the EDID of the last output selected to it. If all your displays are the same, or all displays are capable of running at the same resolution then this step does not matter.

## RMT16-IR Installation

---

1. Remove battery cover from the back of the RMT16-IR remote.
2. Verify that dip switches 1 & 2 are in the down (OFF) position.
3. Insert the battery, hold the battery so that you can see the positive side facing up. The side that is not marked must be facing down.
4. Test the RMT16-IR remote by pressing **ONLY** one button at a time. The indicator light on the remote will flash once each time you press a button. **WARNING:** Do not press multiple buttons simultaneously and do **NOT** press buttons rapidly. These actions will cause the remote to reset and steps 1-4 will have to be repeated.

Note: The RMT16-IR ships with two batteries. One battery is required for operation, the second battery is complimentary.

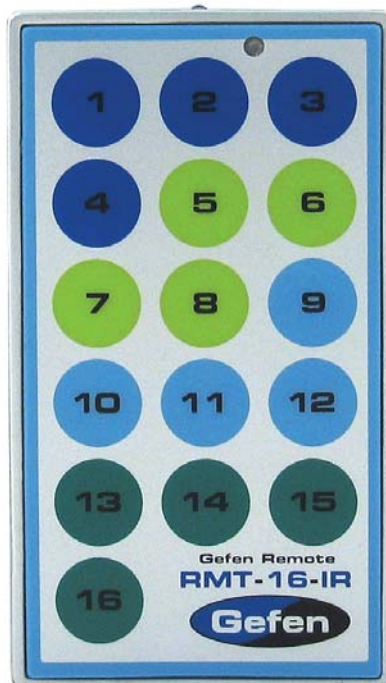

## DIP SWITCH GUIDELINES

Inside the 4x4 HDMI Matrix is a bank of Dip Switches. Below is a table describing their functions. By default, all switches are set to the Off position.

Dip Switch #	Name	Description
1	Switching Delay	Adds a 3 second delay to switching
2	On Board EDID	Feeds a Generic HDMI EDID (720p/1080i) to all Inputs
3	IR Code Dip Switch	Corresponds to Dip Switch 1 on RMT16-IR
4	IR Code Dip Switch	Corresponds to Dip Switch 2 on RMT16-IR
5	Unused	
6	Unused	
7	Unused	
8	Edge Select	+Edge Pixels

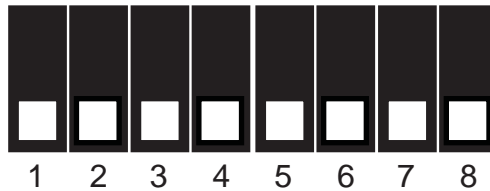

### How to open the 4x4 HDMI Matrix:

To access the dip switches, first remove the 10 hex nuts on the back of the unit (8 located above each HDMI port and 2 adjacent to the RS232 port). Remove the 5 Philips screws under the unit and the 4 screws on each side of the unit. Now carefully remove the cover of the 4x4 HDMI Matrix.

## IR CODES

---

In the event of IR conflicts, please do the following:

1. Remove the battery cover from the back of the RMT16-IR remote.
2. Locate the Dip Switches above the batteries
3. Switch the Dip Switches on the RMT16-IR to any of the combinations pictured below.
4. Dip Switches 1 and 2 in the RMT16-IR correspond with Dip Switches 3 and 4 inside the 4x4 HDMI Matrix respectively. Switch the switches inside the 4x4 HDMI Matrix to match the same Remote Channel as the RMT16-IR. The 4x4 Matrix is now set to a new IR Code.

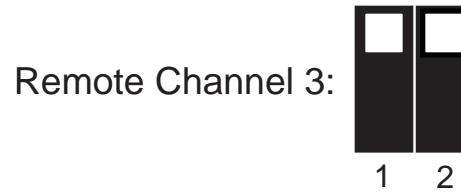
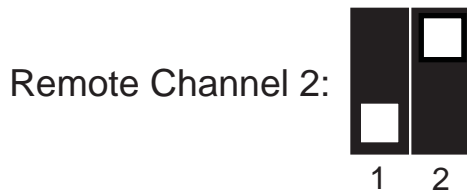
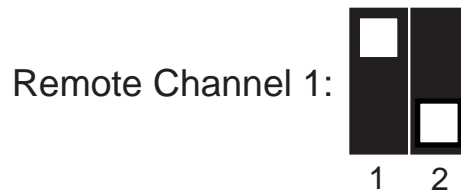
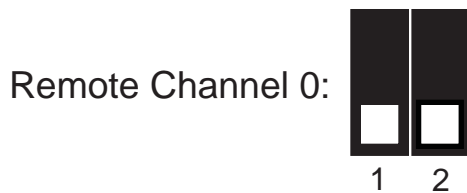

# RS-232 INTERFACE

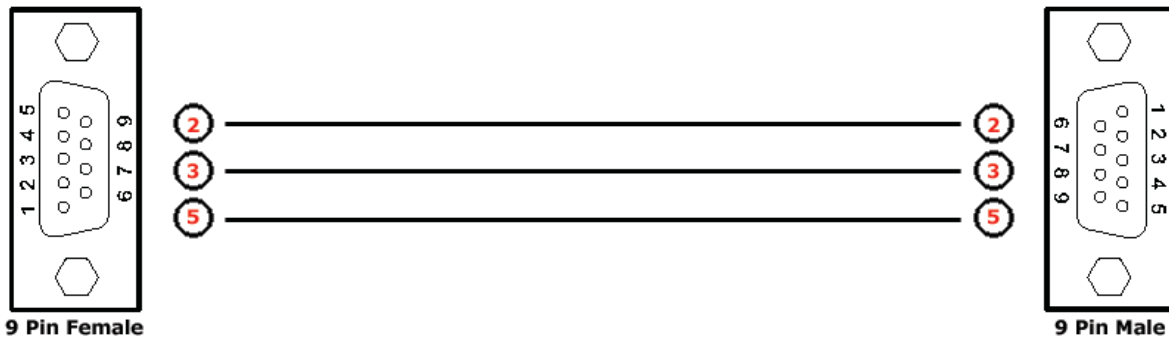

## Binary Table

ASCII	Corresponding RMT16-IR Button	Binary	ASCII	Corresponding RMT16-IR Button	Binary
1	1	0011 0001	9	9	0011 1001
2	2	0011 0010	a	10	0110 0001
3	3	0011 0011	b	11	0110 0010
4	4	0011 0100	c	12	0110 0011
5	5	0011 0101	d	13	0110 0100
6	6	0011 0110	e	14	0110 0101
7	7	0011 0111	f	15	0110 0110
8	8	0011 1000	g	16	0110 0111

## RS232 Settings

Bits per second ..... 19200

Data bits ..... 8

Parity ..... None

Stop bits ..... 1

Flow Control ..... None

# 4x4 HDMI MATRIX RACK MOUNT DIAGRAM

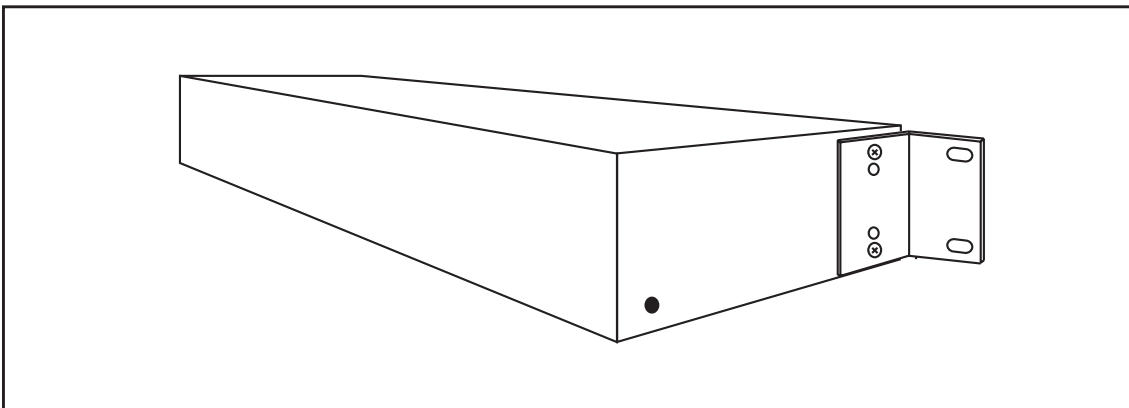
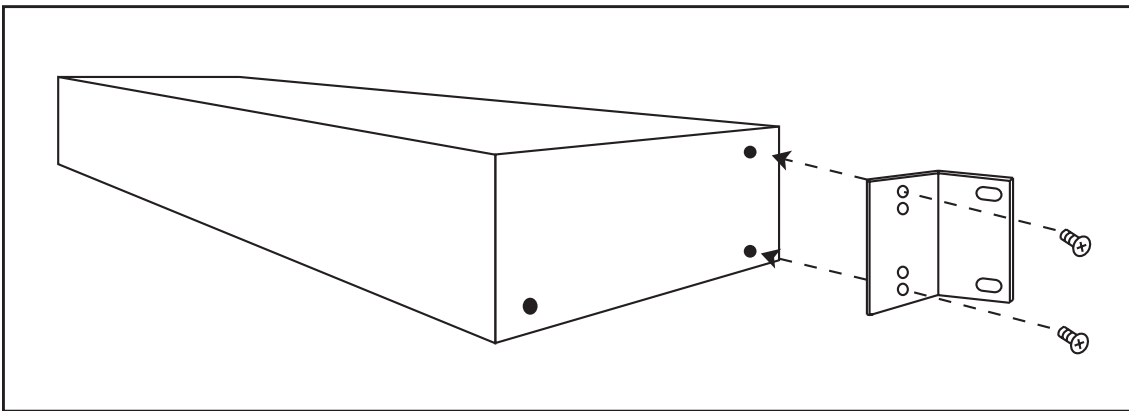
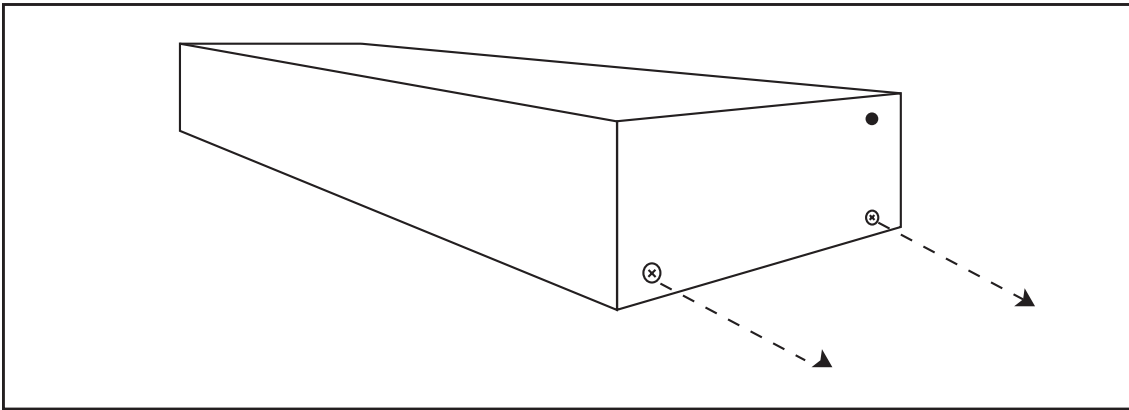
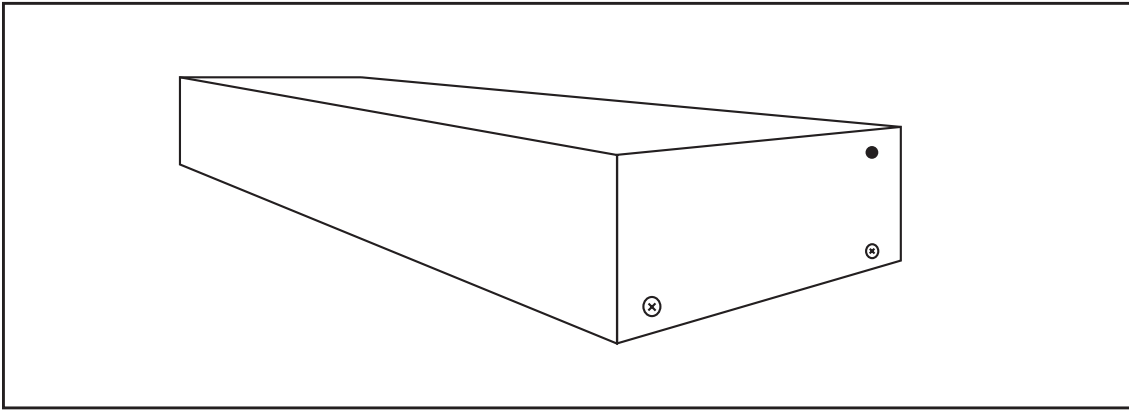

## SPECIFICATIONS

---

Video Amplifier Bandwidth .....	1.65 Gbps
Input Video Signal .....	1.2 volts p-p
Input DDC Signal .....	5 volts p-p (TTL)
Single Link Range .....	1080p / 1920 x 1200
HDMI Input/Output Connector .....	Type A 19-pin Female
Remote Control Port .....	RS-232 Female, Mini-Stereo
Power Consumption .....	60 watts (max)
Power Supply .....	24V DC
Dimensions .....	17" W x 1.75" H x 5.875" D
Shipping Weight .....	10 lbs.

## TERMINOLOGY

---

### ***DDC***

Short form for Display Data Channel. It is a VESA standard for communication between a monitor and a video adapter. Using DDC, a monitor can inform the video card about its properties, such as maximum resolution and color depth. The video card can then use this information to ensure that the user is presented with valid options for configuring the display.

### ***DDWG***

Digital Display Working Group DDWG are the creators of the DVI specification.

### ***DVI***

Digital Visual Interface. Connection standard developed by Intel for connecting computers to digital monitors such as flat panels and DLP projectors. A consumer electronics version, not necessarily compatible with the PC version, is used as a connection standard for HDTV tuners and displays. Transmits an uncompressed digital signal to the display. The latter version uses HDCP copy protection to prevent unauthorized copying.

### ***HDCP***

High-Bandwidth Digital Content Protection. Created by Intel, HDCP is used with HDTV signals over DVI and HDMI connections and on D-Theater D-VHS recordings to prevent unauthorized duplication of copy written material.

### ***HDMI***

The High-Definition Multi-media Interface (HDMI) is an industry-supported, uncompressed, all-digital audio/video interface. HDMI provides an interface between any compatible digital audio/video source, such as a set-top box, DVD player, and A/V receiver and a compatible digital audio and/or video monitor, such as a digital television (DTV).

### ***HDTV***

High-Definition Television. The high-resolution subset of our DTV system. The ATSC defines HDTV as a 16:9 image with twice the horizontal and vertical resolution of our existing system, accompanied by 5.1 channels of Dolby Digital audio. The CEA defines HDTV as an image with 720 progressive or 1080 interlaced active (top to bottom) scan lines. 1280:720p and 1920:1080i are typically accepted as high-definition scan rates.

### ***RS-232***

Recommended Standard 232. This is the de facto standard for communication through PC serial ports. It can refer to cables and ports that support the RS232 standard.

### ***VESA***

Video Electronic Standards Association, a consortium of manufacturers formed to establish and maintain industry wide standards for video cards and monitors. VESA was instrumental in the introduction of the Super VGA and Extended VGA video graphics standards with a refresh rate of 70 Hz, minimizing flicker and helping to reduce user eyestrain and fatigue.

## WARRANTY

---

Gefen Inc. warrants the equipment it manufactures to be free from defects in material and workmanship.

If equipment fails because of such defects and Gefen Inc. is notified within one (1) year from the date of shipment, Gefen System will, at its option, repair or replace the equipment, provided that the equipment has not been subjected to mechanical, electrical or other abuse or modifications.

Equipment that fails under conditions other than those covered will be repaired at the current price of parts and labor in effect at the time of repair. Such repairs are warranted for ninety (90) days from the day of shipment to the Buyer.

This warranty is in lieu of all other warranties expressed or implied, including without limitation, any implied warranty or merchantability or fitness for any particular purpose, all of which are expressly disclaimed.

The information in this manual has been carefully checked and is believed to be accurate. However, Gefen Inc. assumes no responsibility for any inaccuracies that may be contained in this manual. In no event will Gefen Inc., be liable for direct, indirect, special, incidental, or consequential damages resulting from any defect or omission in this manual, even if advised of the possibility of such damages. The technical information contained herein regarding the 4x4 HDMI Matrix features and specifications is subject to change without notice.